

SF2759K

**1575.42 MHz
SAW Filter**

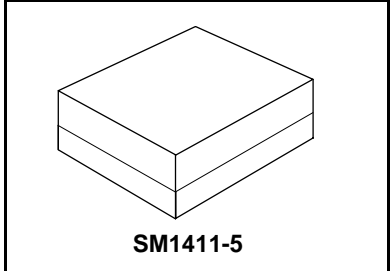

- RF Filter Designed for Front End GPS Applications
- Excellent Rejection
- 1.4 x 1.1 mm Surface-Mount Case
- Complies with Directive 2002/95/EC (RoHS)
- Moisture Sensitivity Level - MSL3

Absolute Maximum Ratings

Rating	Value	Units
Maximum Incident Power in Passband	+15	dBm
Maximum DC Voltage On any Non-ground Terminal	3	VDC
Operating Temperature Range	-40 to +105	°C
Component Storage Temperature Range	-40 to +105	°C
Storage Temperature Range in Tape and Reel	-40 to +85	°C

Electrical Characteristics

Characteristic	Sym	Notes	Min	Typ	Max	Units
Center Frequency	f_c			1575.42		MHz
2 dB Bandwidth				40		MHz
Insertion Loss, 1574.42 to 1576.42 MHz	IL_{MAX}			1.0	1.8	dB
Amplitude Ripple, 1574.42 to 1576.42 MHz				0.1	1.0	dB
Rejection Referenced to IL_{MAX}						
DC to 1450 MHz			33	35		dB
1450 to 1520 MHz			30	42		
1625 to 1640 MHz			35	38		
1640 to 1805 MHz			34	36		
1805 to 1910 MHz			34	37		
1910 to 2000 MHz			34	38		
2000 to 4000 MHz			30	32		
4000 to 6000 MHz			20	23		
VSWR, 1574.42 to 1576.42 MHz				1.25	1.8	
Terminating Source impedance	Z_s			50		Ω
Terminating Load impedance	Z_L			50		Ω
Case Style				SM1411-5		
Lid Symbolization \square = year/month manufacturing code				K		

 **CAUTION: Electrostatic Sensitive Device. Observe precautions for handling.**

NOTES:

1. The design, manufacturing process, and specifications of this device are subject to change.
2. US or International patents may apply.
3. RoHS compliant from the first date of manufacture.

Frequency Response Plots

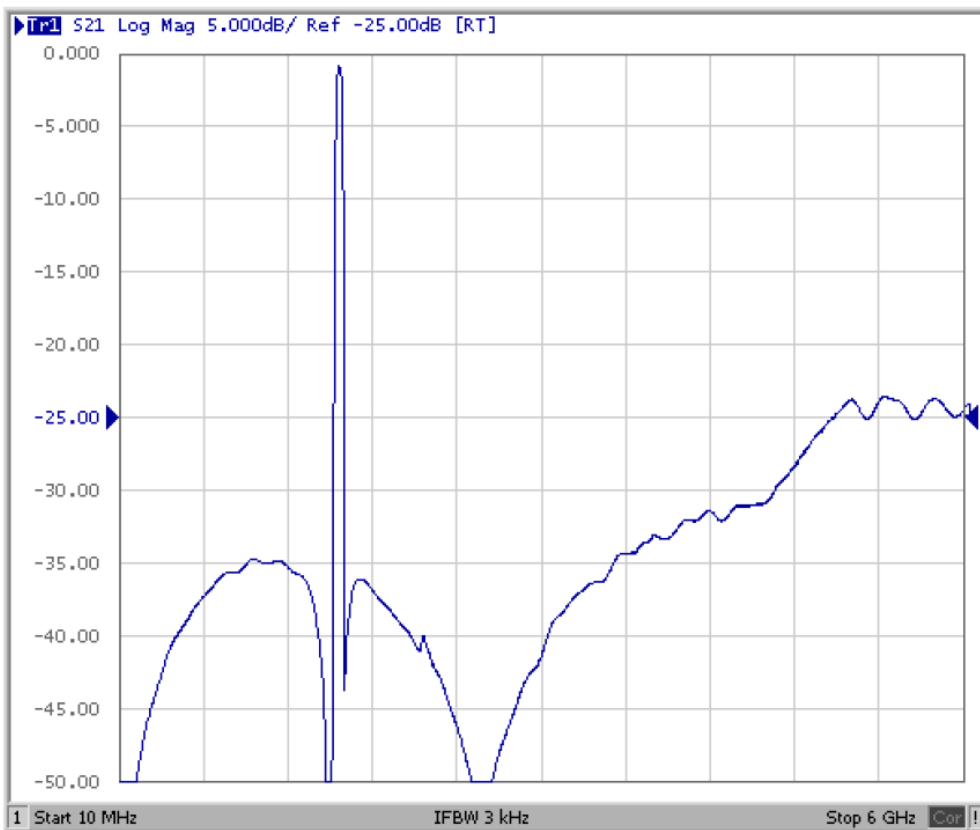
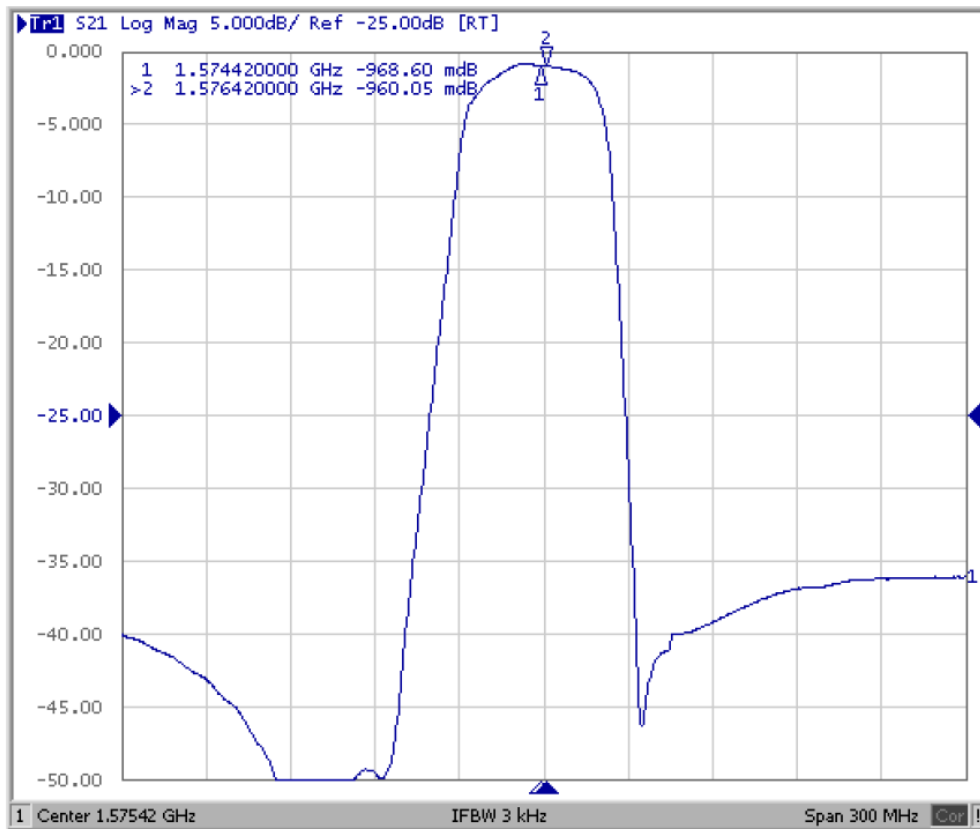

Input VSWR Plot

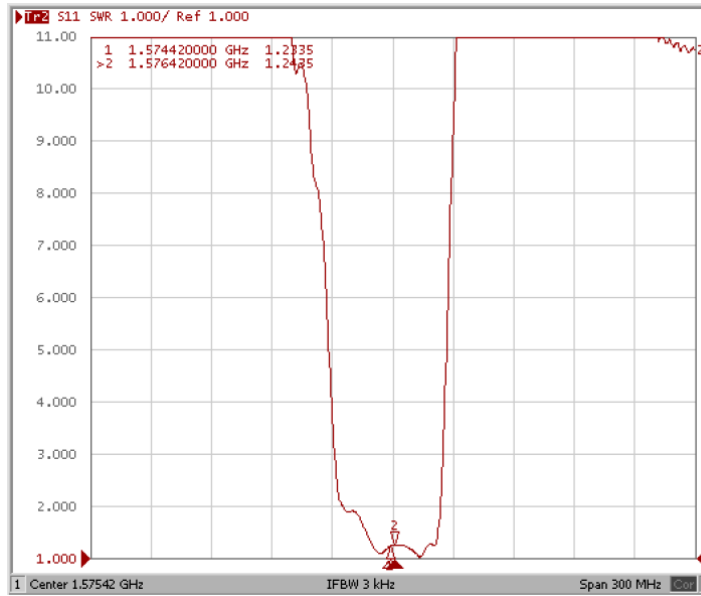

Output VSWR Plot

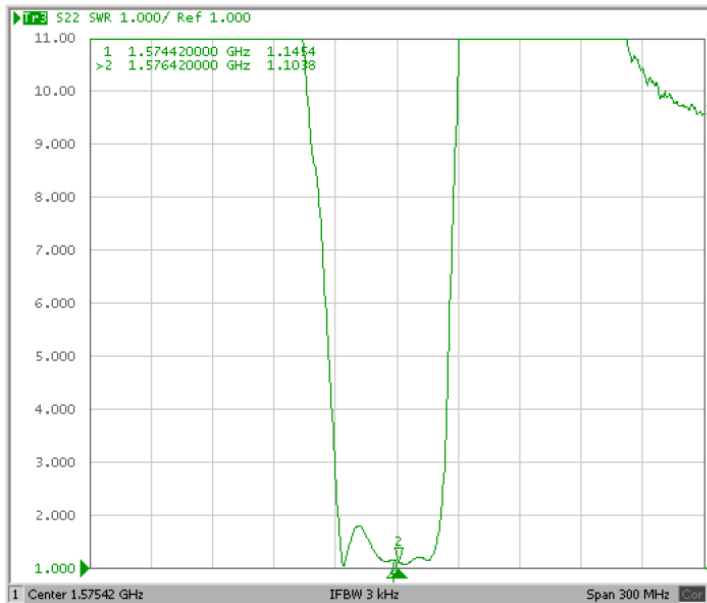

SM1411-5 Case

5-Terminal Surface-Mount Case 1.45 X 1.15- mm Nominal Footprint

Electrical Connections

Connection	Terminals
Input	1
Output	4
Ground	2, 3, 5

Package Dimensions

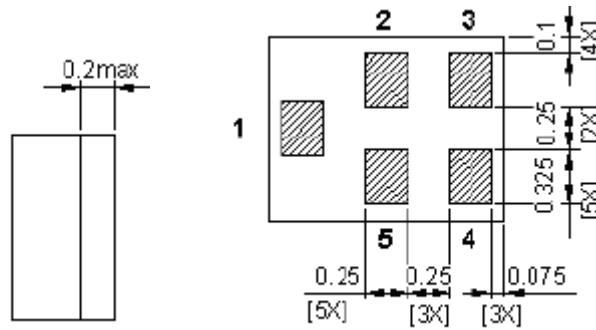
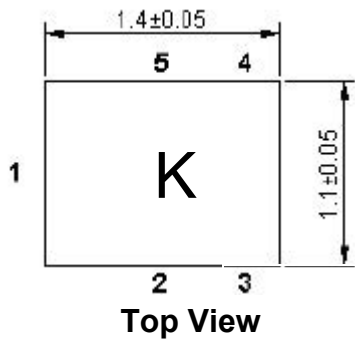

Bottom View

All tolerances are ± 0.05 mm unless otherwise specified
Coplanarity : 0.1 mm max.
1 to 5 : Pin No.
Unit : mm

Circuit Board Footprint

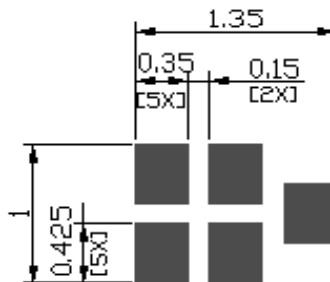

Test Circuit

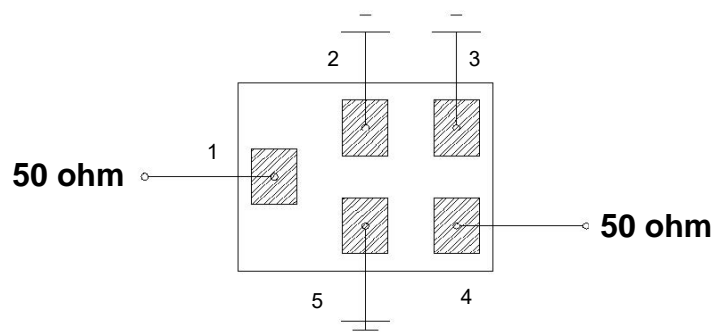

Reel Dimensions - 7 inch Reel, 3000 Filters

Tape and Reel Standard per ANSI/EIA-481

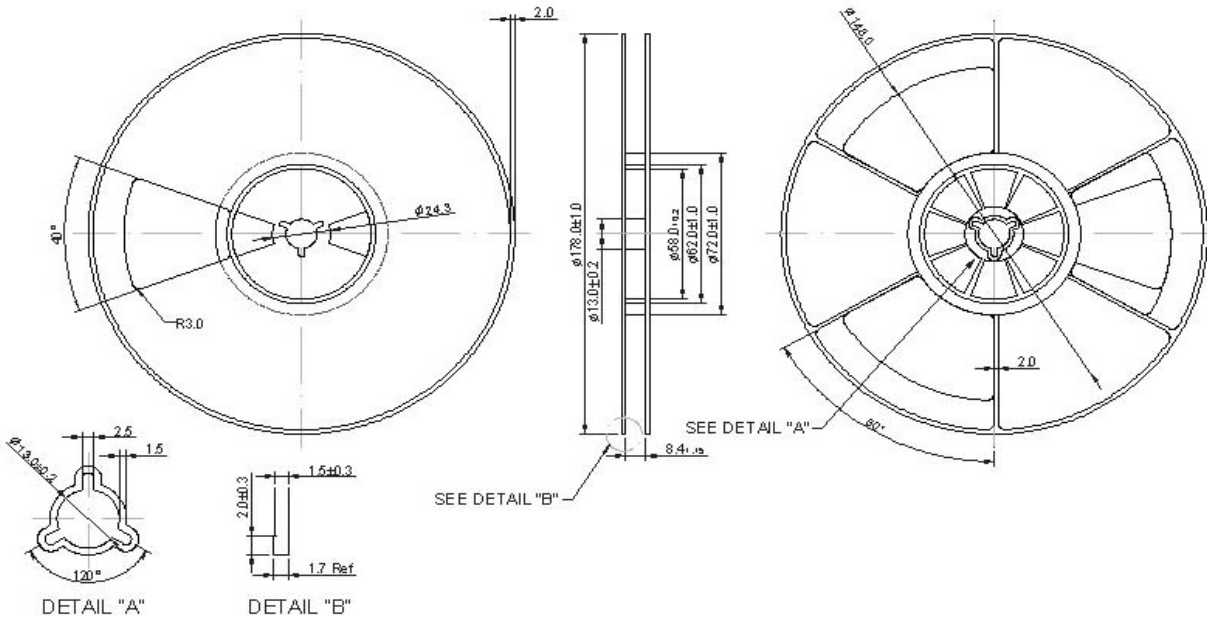

Tape Dimensions

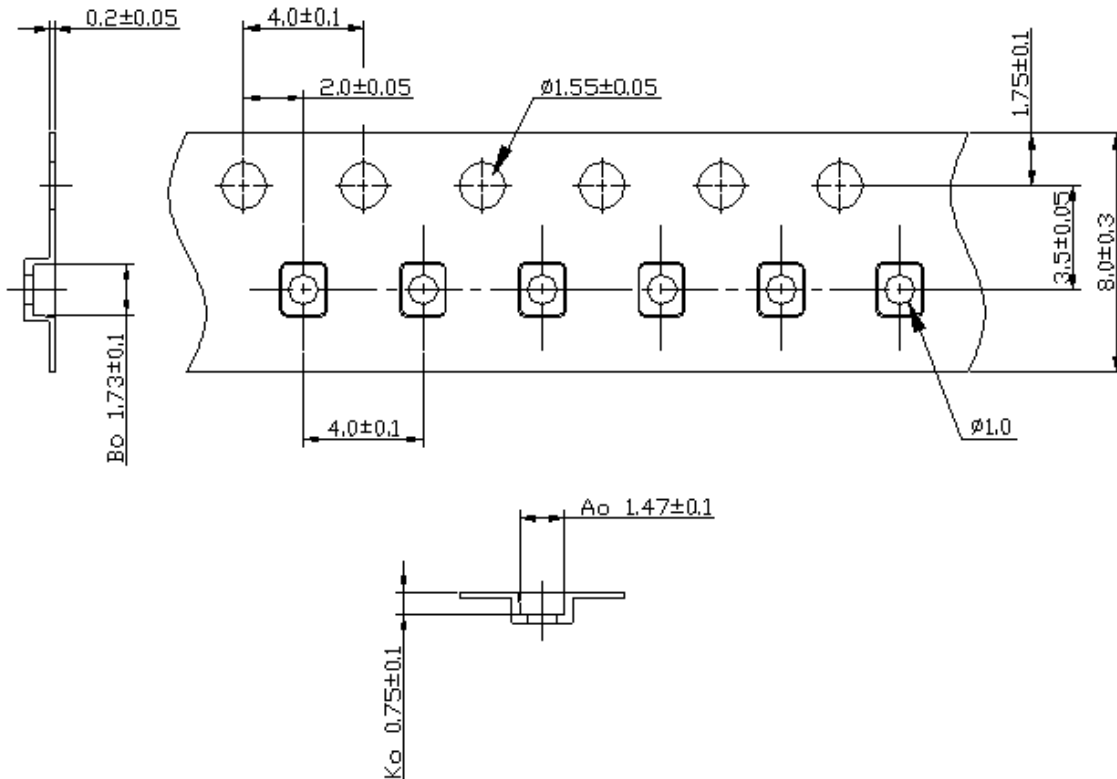

Recommended Reflow Profile

1. Preheating shall be fixed at 150~180°C for 60~90 seconds.
2. Ascending time to preheating temperature 150°C shall be 30 seconds min.
3. Heating shall be fixed at 220°C for 50~80 seconds and at 260°C +0/-5°C peak (20 - 40 seconds).
4. Time: 2 times maximum.

